

**Electric
Self-Propelled
Articulating
Boom**

Z-20/8N

An industry first!

Small booms
packed with
big ideas.



Genie Industries

Z-20/8N

Small booms packed with big ideas.

- With a base width of only 32 in (81 cm), the Z-20/8N allows **access in confined work areas and easily drives through standard single doors.**
- **Articulating jib rotates 180°** and allows you to position the jib exactly where you need it.
- **No tailswing**—the lift linkage does not extend past the drive chassis and does not rotate.
- Proportional lift and drive functions allow **smooth operation and easy positioning in tight areas.**
- Multiple disc brakes provide **smooth, controlled deceleration.**

- Roll-out trays provide **easy access to batteries and hydraulic subassembly.**

Standard Features

- 26 ft (7.9 m) working height
- 8 ft 8 in (2.64 m) horizontal reach
- Compact 32 in (81 cm) width
- Articulating jib rotates 180° and has 144° working range
- 400 lb (181 kg) lift capacity
- 180° platform rotation
- Proportional drive and lift
- Solid rubber non-marking tires
- AC wiring to platform
- High angle steering
- Multiple disc brakes
- Manual brake release pump
- Maintenance-free pivot-point bearings
- Auxiliary power unit
- Hour meter

Range of Motion

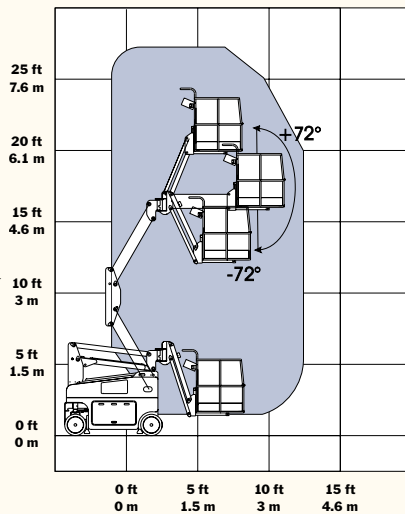

Options and Accessories

- Alarm package
- Air line to platform
- Battery charge indicator
- Platform swing gate

Standards Compliance

- ANSI/SIA A92.5
- CSA CAN3-B354.4-M82
- CE compliance option
- AS 1418.10

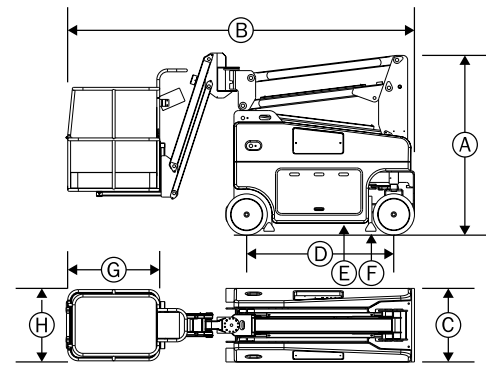

Specifications

	Z-20/8N	
	US	Metric
Working height max	26 ft	7.9 m
Platform height max	20 ft	6.1 m
(A) Height - stowed	6 ft 7 in	2 m
(B) Length - stowed	12 ft 4 in	3.76 m
(C) Width	32 in	81 cm
(D) Wheelbase	5 ft 4 in	1.63 m
(E) Ground clearance	5 in	13 cm
- at machine center		
(F) Ground clearance	2 in	5 cm
- at pothole bars		
(G) Platform length	40 in	1 m
(H) Platform width	31 in	79 cm
Horizontal reach max	8 ft 8 in	2.64 m
Up and over clearance	16 ft 1½ in	4.9 m
Lift capacity		
ANSI, CSA	400 lb	181 kg
CE	440 lb	200 kg
Turning radius (outside)	4 ft 9 in	1.45 m
Turning radius (inside)	10 in	25 cm
Tailswing (at pivotal height)	zero	
Tailswing (stowed position)	zero	
Platform rotation	180°	180°
Jib range of motion	144°	144°
Power source	48V (8 6V 245 AH batteries)	
Drive speed - stowed	0-2.6 mph (high)	0-4.2 km/h (high)
	0-1.3 mph (low)	0-2.1 km/h (low)
Drive speed - raised	0-0.6 mph	0-1 km/h
Controls	proportional drive and lift	
AC wiring to platform	standard	
Auxiliary power unit	standard	
Non-marking tires (solid rubber: treaded)	18 x 14 x 6 in	46 x 36 x 15 cm
Tire load range	4,130 lb	1,873 kg
Gradeability	18%	18%
Hydraulic tank capacity	8 gal	30 litre
Weight	10,750 lb	4,876 kg

Distributed By:

Genie Industries

GENIE UNITED STATES

18340 NE 76th Street
P.O. Box 97030
Redmond, Washington 98073-9730
Telephone (425) 881-1800
Toll Free in USA/Canada 800-536-1800
Fax (425) 883-3475
<http://www.genielift.com>

GENIE UNITED KINGDOM

The Maltings, Wharf Road
Grantham
Lincolnshire NG31 6BH
England
Telephone (44) 01476-584333
Fax (44) 01476-584334
<http://www.genielift.com>